

AT355

TOP VIEW

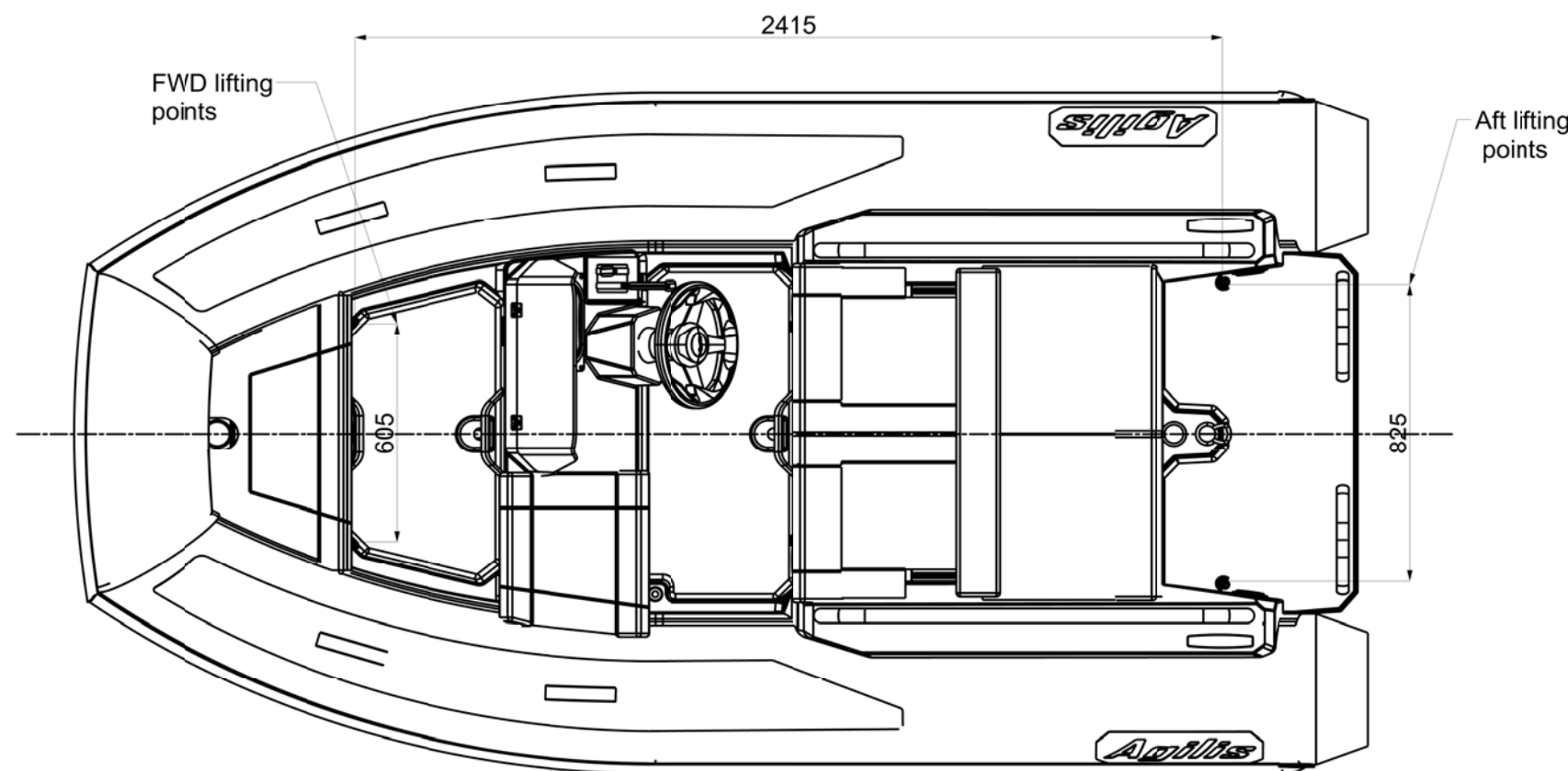

AFT VIEW

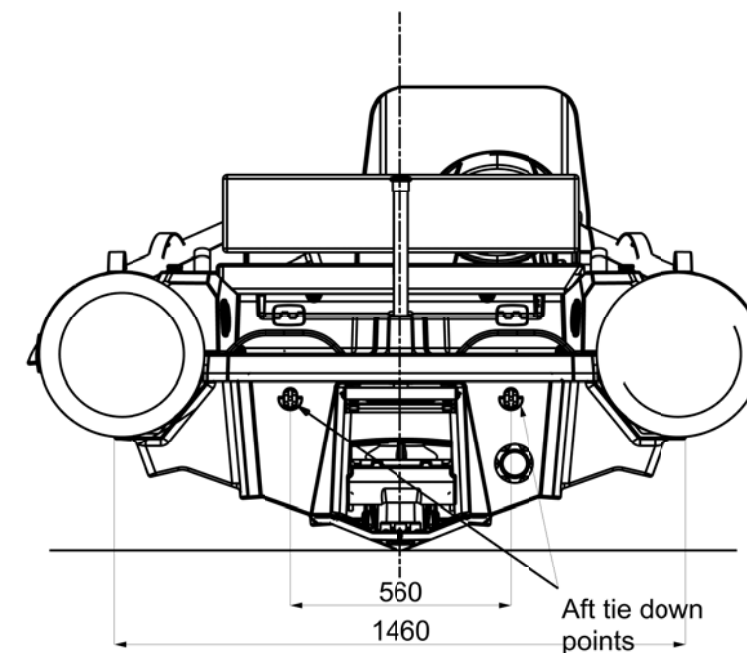

SIDE VIEW

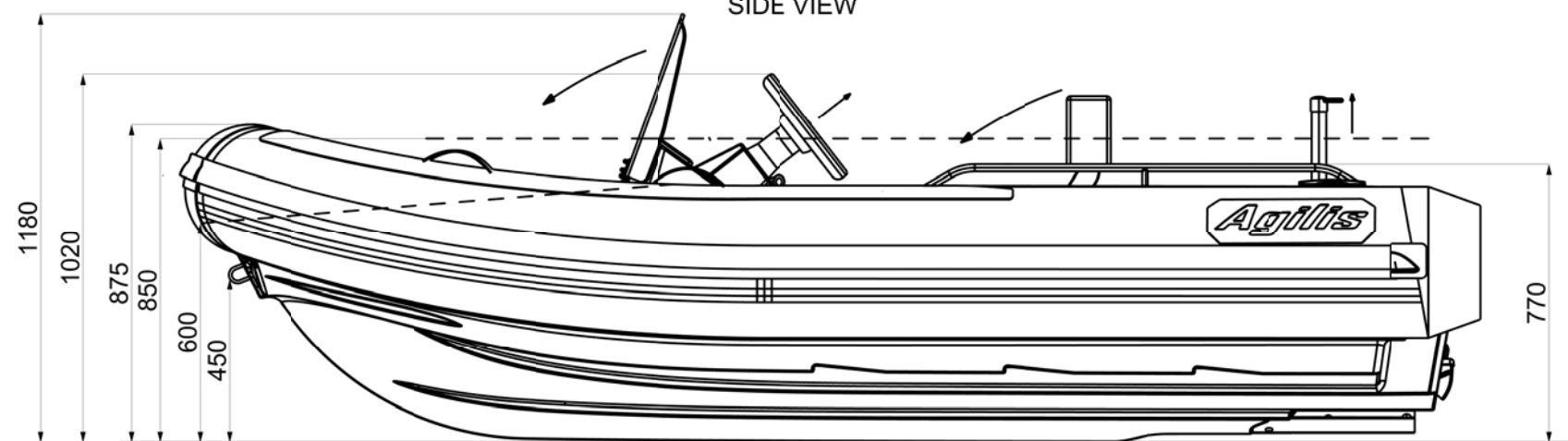

Technical data:

1. Length Overall:.....3.55 m, +/-1%
2. Beam Overall:.....1.85 m, +/-1%
3. Seating capacity:.....6
4. Engine: 1) Rotax 900 ACE (90 HP/66 kW)
2) Rotax 1603 (130 HP/95.6 kW)
5. Light craft mass : 1).....390 kg
2).....420 kg
6. Maximum load: 1).....529 kg (fuel excluded)
2).....505 kg (fuel excluded)
7. Maximum speed, V = 37 knots
8. CE Design Category "C"
9. Propulsion: Jet drive
10. Fuel tank capacity:55 litres, petrol
11. No. of tube Compartments:..... 4

UNLESS OTHERWISE SPECIFIED: DIMENSIONS ARE IN MILLIMETERS SURFACE FINISH: TOLERANCES: LINEAR: ANGULAR:		FINISH:		DEBURR AND BREAK SHARP EDGES		DO NOT SCALE DRAWING		REVISION	
DRAWN						TITLE: AT355 - General Arrangement			
CHK'D						DWG NO. AT355-000-001			
APP'VD						SCALE: 1:20			
MFG						SHEET 1 OF 1			
Q.A						A3			
MATERIAL:									
WEIGHT:									