

AT360

SIDE VIEW

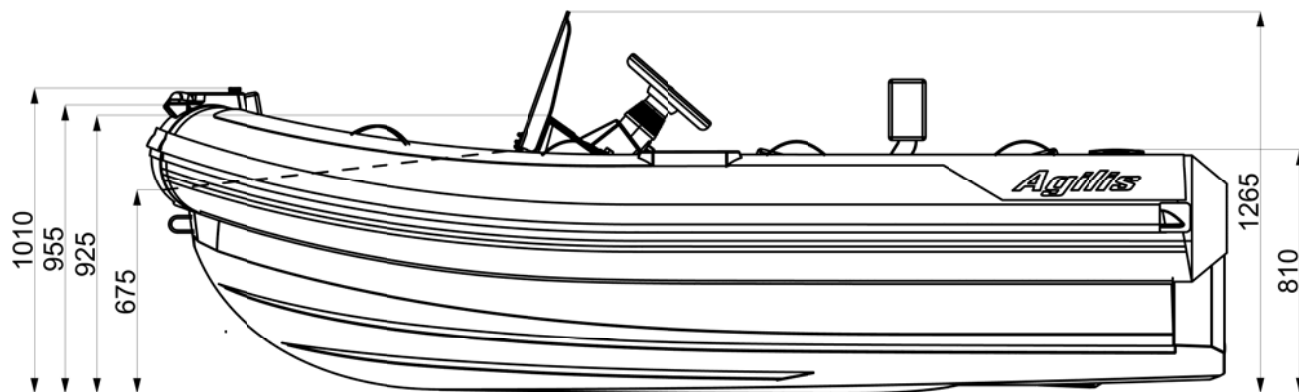

AFT VIEW

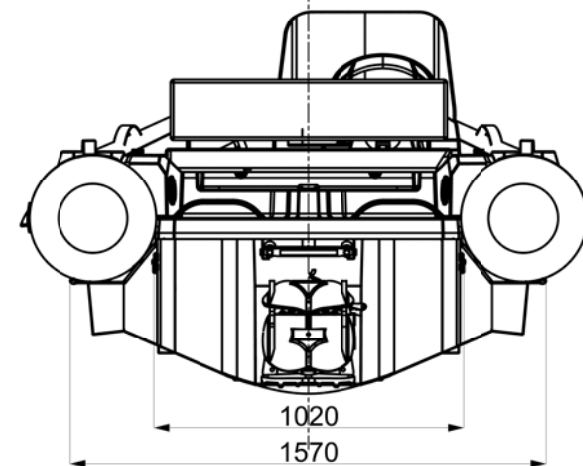

TOP VIEW

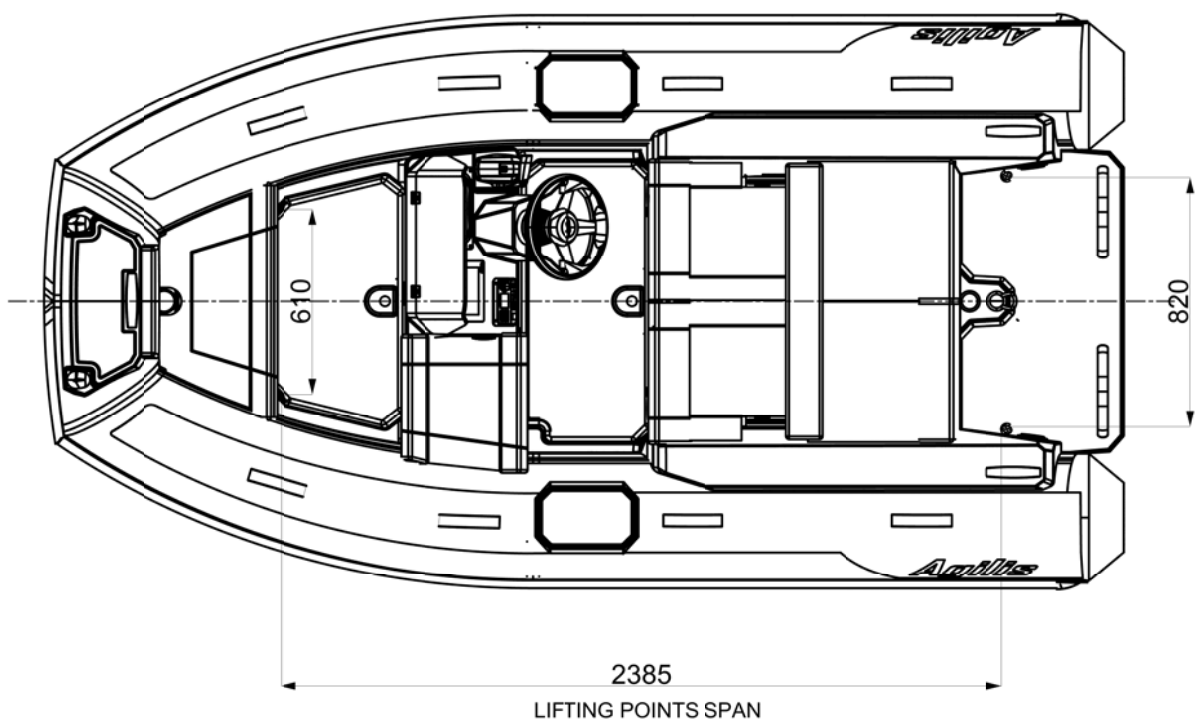

Technical data:

Marine grade aluminium hull, GRP deck

1. Length Overall: 3.60 m, +/-1%
2. Beam Overall: 1.77 m, +/-1%
3. Seating capacity: 6
4. Light craft mass: 595 kg
5. Maximum load: 490 kg (fuel excluded)
6. Maximum speed, V = 36 knots
7. CE Design Category "C"
8. Engine: FNM DESEL (110 HP/81 kW)
9. Propulsion: Jet drive
10. Fuel tank capacity: 60 litres, diesel
11. No. of tube Compartments: 4

UNLESS OTHERWISE SPECIFIED FINISH: DIMENSIONS ARE IN MILLIMETERS		DEBURR AND BREAK SHARP EDGES		DO NOT SCALE DRAWING		REVISION
SURFACE FINISH: TOLERANCES: LINEAR: ANGULAR:				This drawing is the property of Agilis Jet Tenders GmbH Lohmstr. 21 52428 Jülich. This information must be reproduced, distributed, or used for any purpose other than in conjunction with its boat or design for which it was drawn, without the owner's written consent.		TITLE: AT360 - General Arrangement
DRAWN	NAME	SIGNATURE	DATE			DWG NO. AT360-000-001
CHECKED						A2
APPROVED						
MFG						
Q.A.						
				MATERIAL:		
				WEIGHT:		
						SCALE: 1:20
						SHEET 1 OF 1