

# AT560

SIDE VIEW

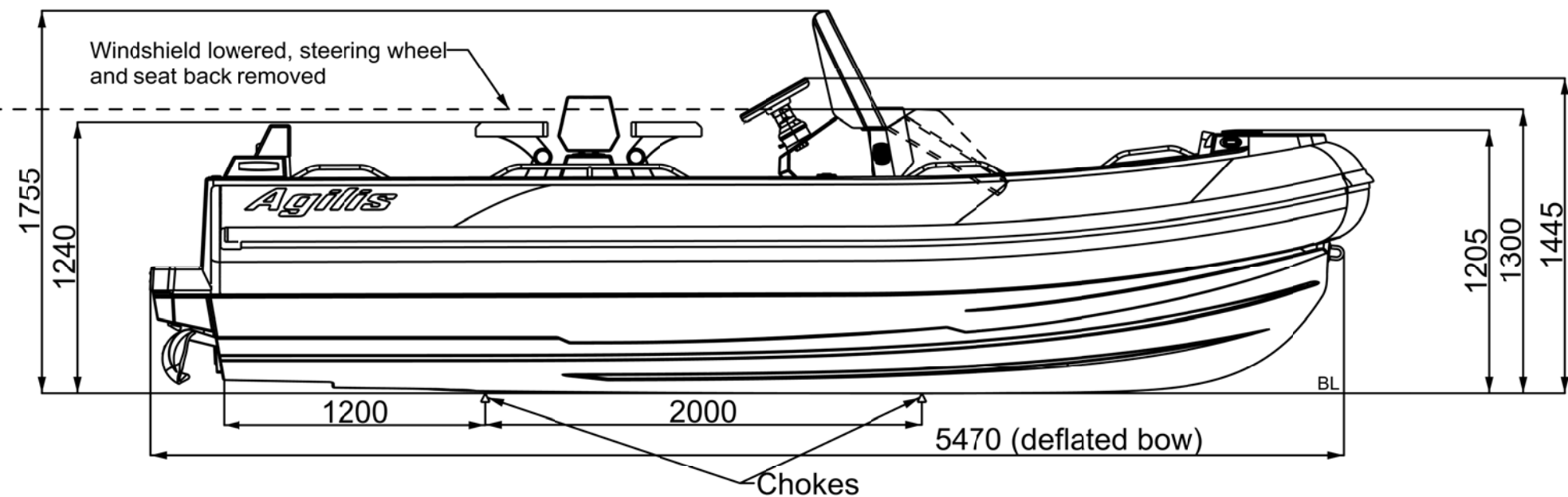

SIDE VIEW (reduced profile with single lifting point, optional)

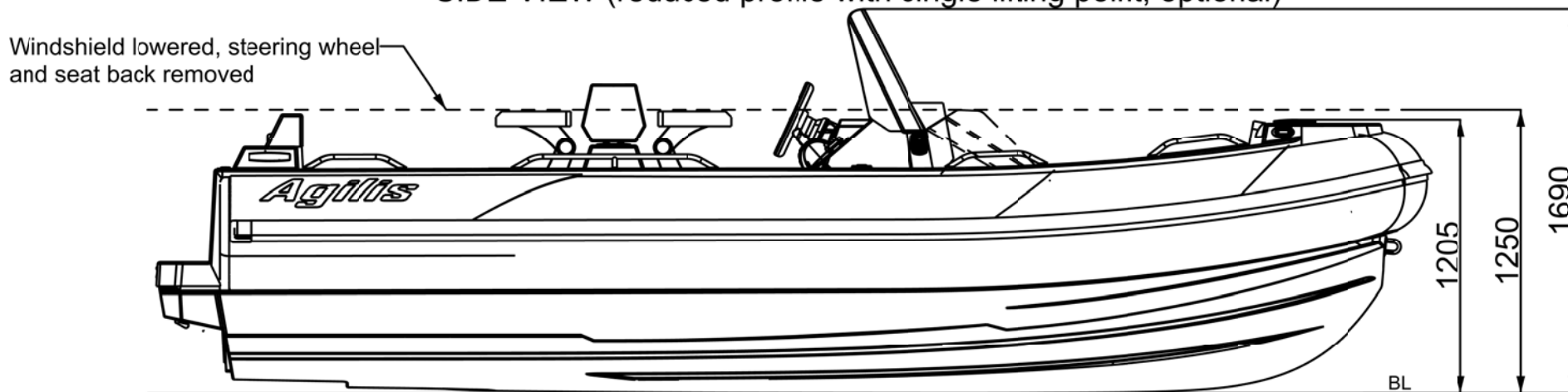

AFT VIEW

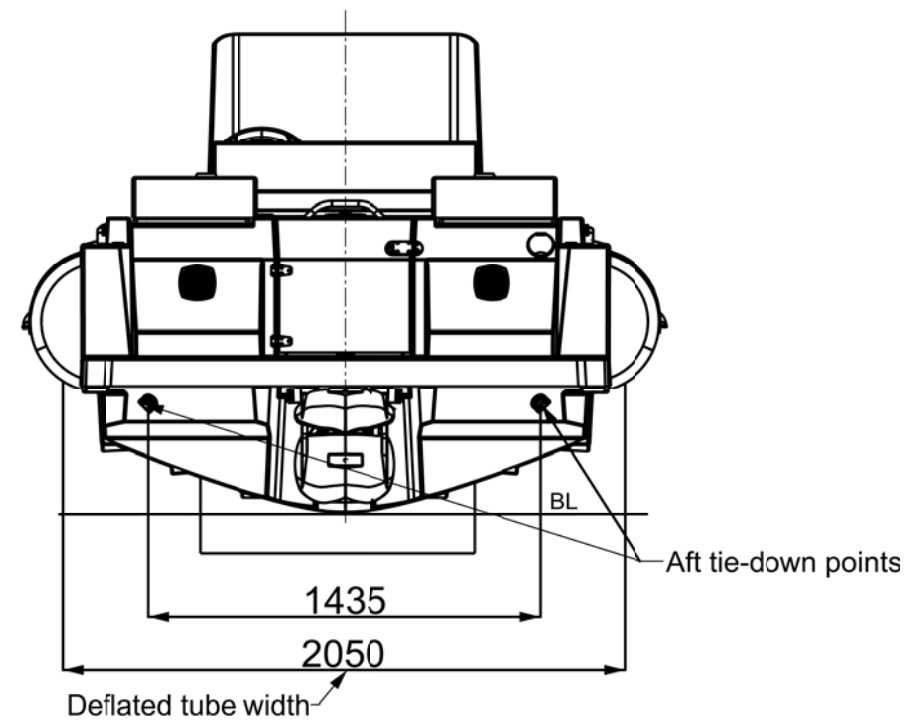

TOP VIEW

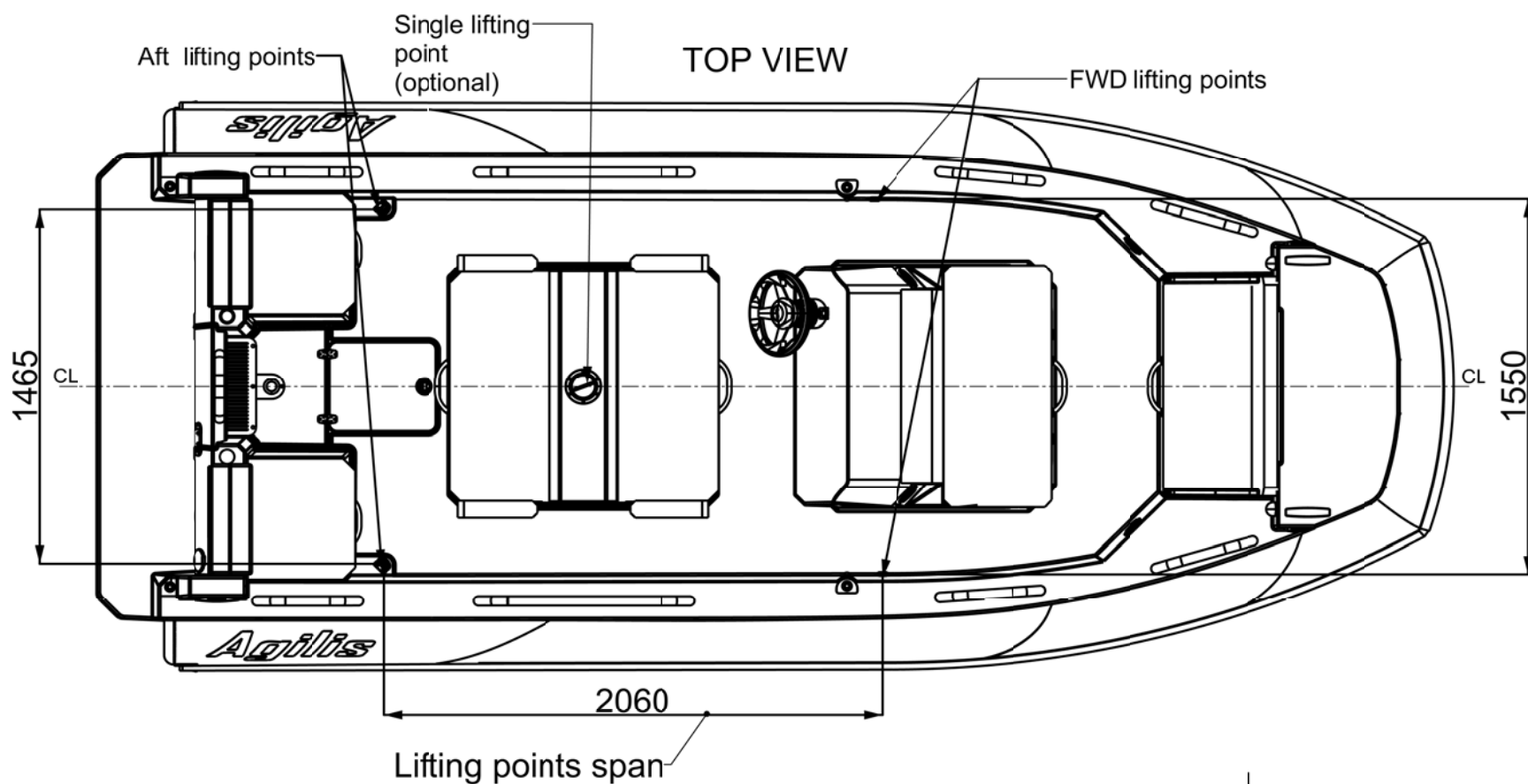

**Technical data:**

- 1.Length Overall:.....5.60 m, +/-1%
- 2.Beam Overall:.....2.35 m, +/-1%
- 3.Seating capacity:.....10
4. Light craft mass:.....1150 kg
5. Maximum load:.....1200 kg (fuel excluded)
6. Maximum speed, V = 38 knots
7. CE Design Category "C"
- 8.Engine: Mercury Diesel 2.0L (170 HP/125kW)  
Mercury Diesel 3.0L (270 HP/198kW) optional
9. Propulsion: Jet drive
10. Fuel tank capacity: .....120 L, diesel
11. No. of tube Compartments:..... 6

UNLESS OTHERWISE SPECIFIED: DIMENSIONS ARE IN MILLIMETERS		FINISH:		DEBURR AND BREAK SHARP EDGES		DO NOT SCALE DRAWING		REVISION	
SURFACE FINISH:						This drawing is the property of Agilis Jet Tenders GmbH/ Lohfeldstr. 2/ 52428 Jülich. This information must not be reproduced, distributed, or used for any purpose other than in conjunction with the boat or design for which it was drawn, without the owner's written consent.			
TOLERANCES:						TITLE:			
LINEAR:						AT560 - General Arrangement			
ANGULAR:						DWG NO.		A2	
						AT560-000-001			
						SCALE:1:20		SHEET 1 OF 1	