

# Agilis 355C

TOP VIEW

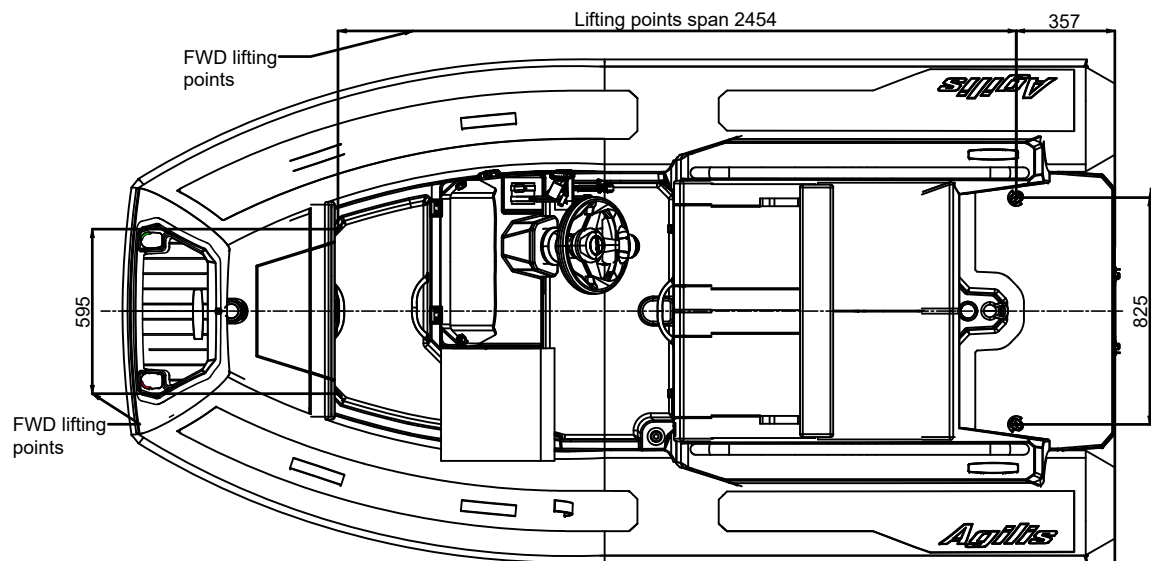

AFT VIEW

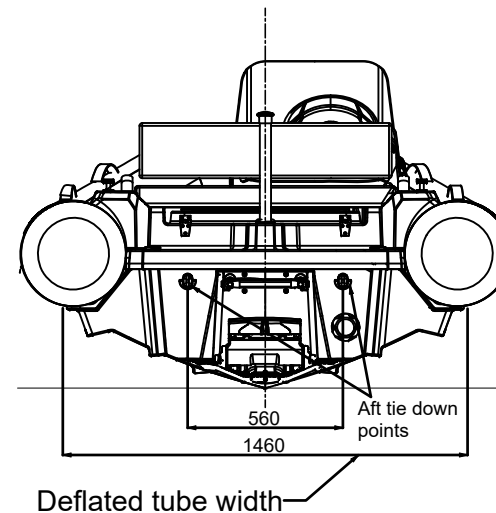

SIDE VIEW

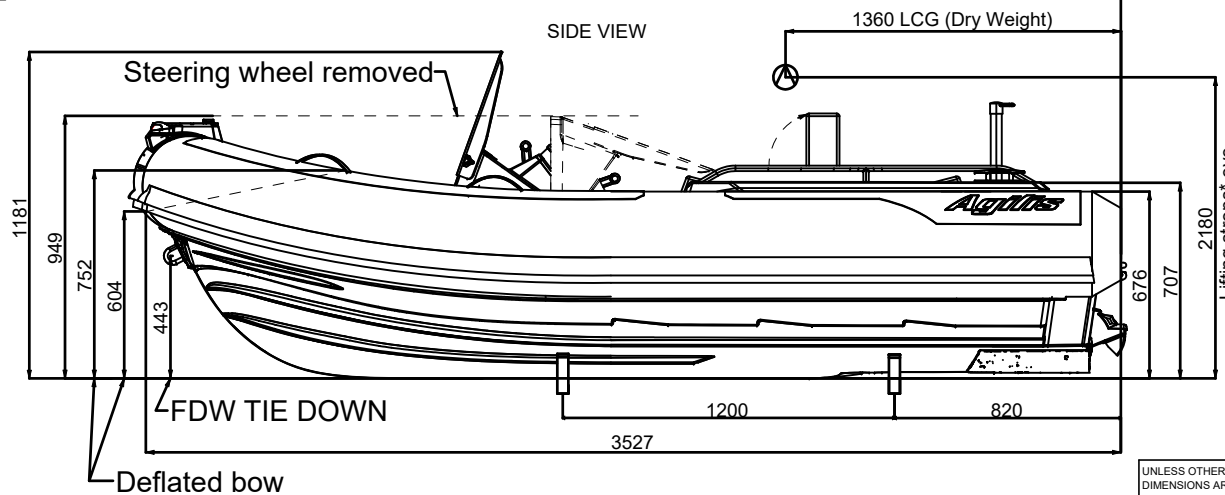

**Technical data:**

1. Length Overall:.....3.55 m, +/-1%
2. Beam Overall:.....1.77 m, +/-1%
3. Seating capacity:.....6
4. Engine: 1) Rotax 900 ACE (90 HP/66 kW)  
2) Rotax 1603 (130 HP/95.6 kW)
5. Light craft mass : 1).....390 kg  
2).....430 kg
6. Maximum load: 1).....529 kg (fuel excluded)  
2).....505 kg (fuel excluded)
7. Maximum speed, V = 37 knots
8. CE Design Category "C"
9. Propulsion: Jet drive
10. Fuel tank capacity: .....55 litres, petrol
11. No. of tube Compartments:..... 4

UNLESS OTHERWISE SPECIFIED: DIMENSIONS ARE IN MILLIMETERS SURFACE FINISH: TOLERANCES:				FINISH:		DEBURR AND BREAK SHARP EDGES		DO NOT SCALE DRAWING		REVISION	
ANGULAR:								This drawing is the property of Agilis Jet Tenders GmbH/ Lothfeldstr 2/ 52438 Jülich. This information must not be reproduced, distributed, or used for any purpose other than in conjunction with the boat or design for which it was drawn, without the owner's written consent.			
LINEAR:	NAME	SIGNATURE	DATE			TITLE: <b>AT355C - General Arrangement</b>					
DRAWN											
CHK'D											
APP'VD											
MFG											
Q.A						MATERIAL:		DWG NO. <b>AT355C-000-001</b>		A3	
						WEIGHT:		SCALE:1:20		SHEET 1 OF 1	