

Agilis 360D

SIDE VIEW

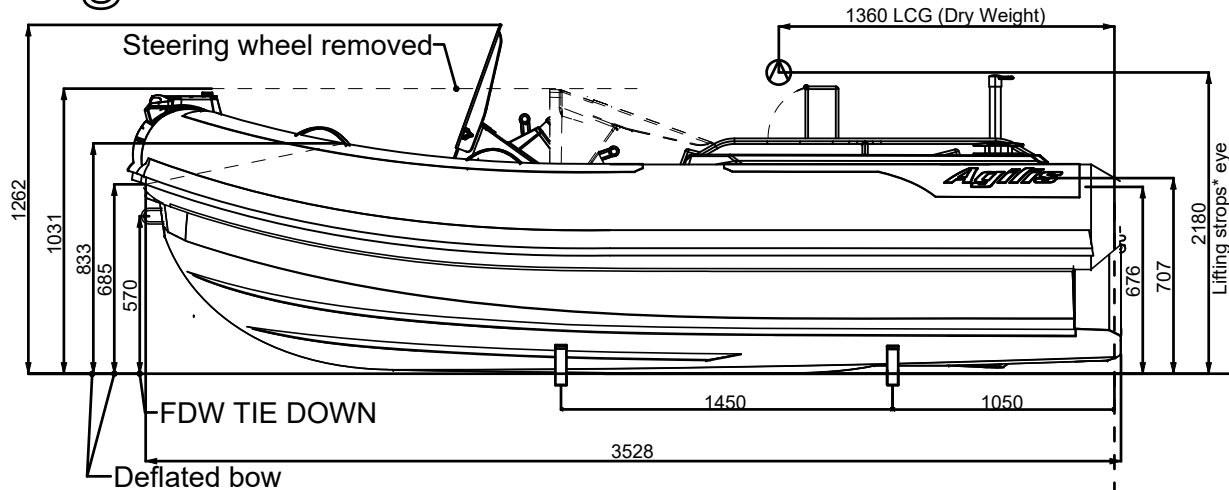

AFT VIEW

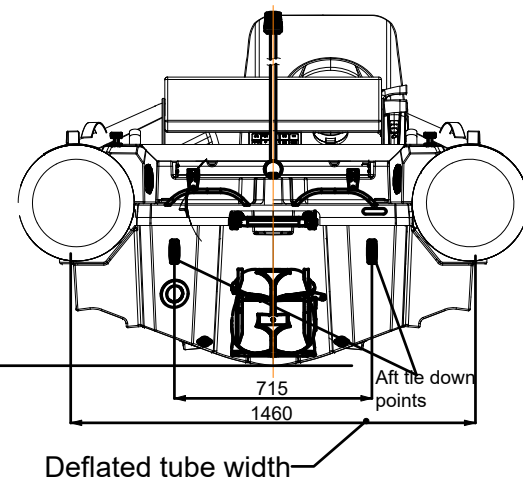

TOP VIEW

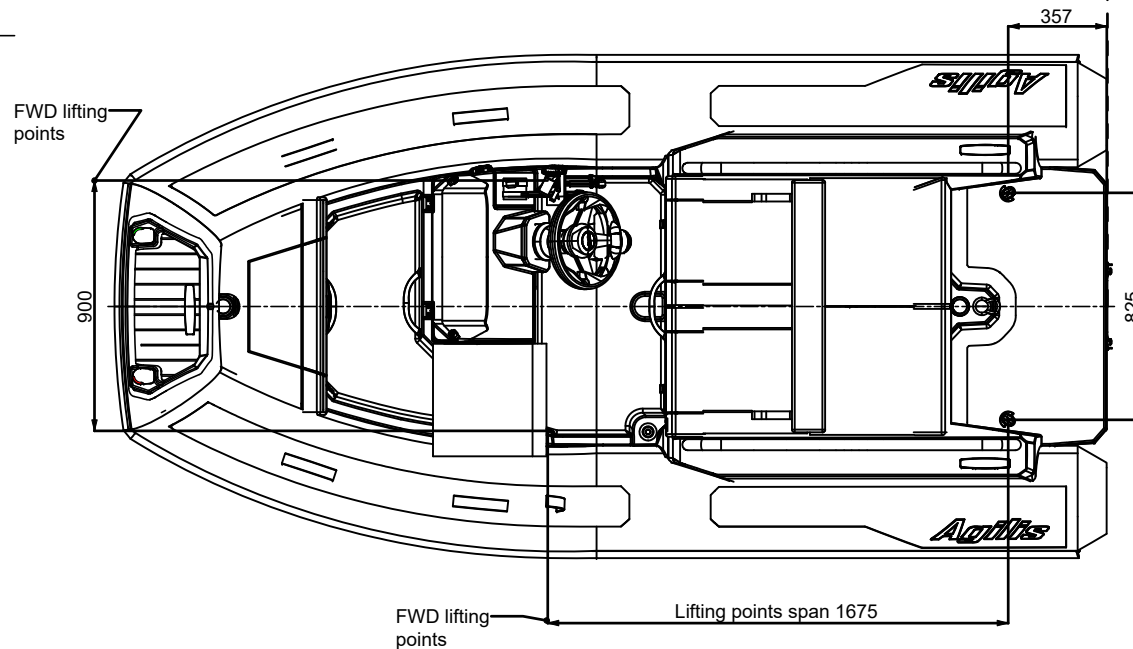

Technical data:

Marine grade aluminium hull, GRP deck

- 1.Length Overall:.....3.60 m, +/-1%
- 2.Beam Overall:.....1.77 m, +/-1%
- 3.Seating capacity:.....6
4. Light craft mass:.....595 kg
5. Maximum load:.....490 kg (fuel excluded)
6. Maximum speed, V = 36 knots
7. CE Design Category "C"
- 8.Engine: FNM DESEL (110 HP/81 kW)
9. Propulsion: Jet drive
10. Fuel tank capacity:60 litres, diesel
11. No. of tube Compartments:..... 4

| | | | | | | | | | | | |
|--|------|-----------|------|---------|--|------------------------------------|--|--|--|--------------|--|
| UNLESS OTHERWISE SPECIFIED: DIMENSIONS ARE IN MILLIMETERS SURFACE FINISH: TOLERANCES: | | | | FINISH: | | DEBURR AND BREAK SHARP EDGES | | DO NOT SCALE DRAWING | | REVISION | |
| ANGULAR: | | | | | | | | This drawing is the property of Agilis Jet Tenders GmbH, Lohfeldstr. 2/ 52438 Jülich. This information must not be reproduced, distributed, or used for any purpose other than in conjunction with the boat or design for which it was drawn, without the owner's written consent. | | | |
| LINEAR: | NAME | SIGNATURE | DATE | | | | | TITLE: AT360D - General Arrangement | | | |
| DRAWN | | | | | | | | | | | |
| CHK'D | | | | | | | | | | | |
| APP'VD | | | | | | | | | | | |
| MFG | | | | | | | | | | | |
| Q.A | | | | | | MATERIAL: | | DWG NO. AT360D-000-001 | | A3 | |
| | | | | | | WEIGHT: | | SCALE:1:20 | | SHEET 1 OF 1 | |