

# AT500

SIDE VIEW

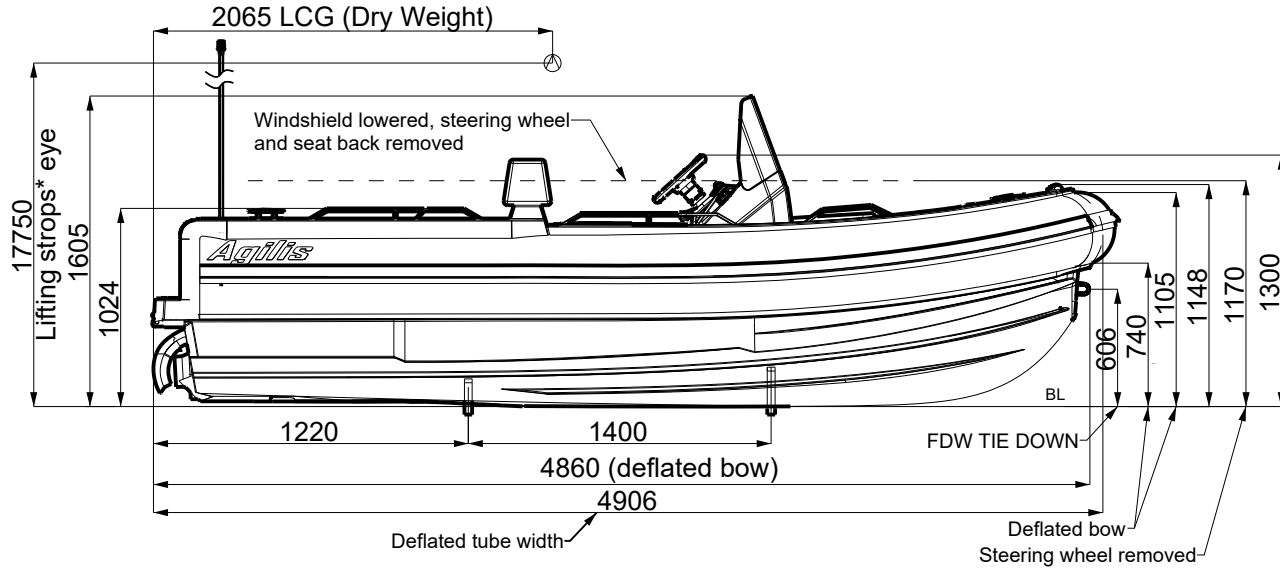

AFT VIEW

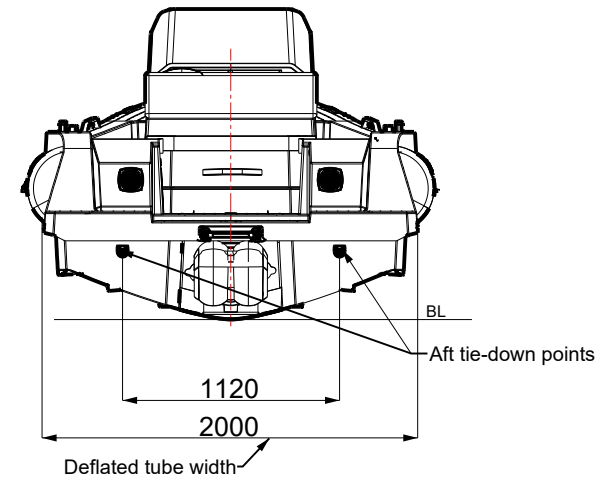

TOP VIEW

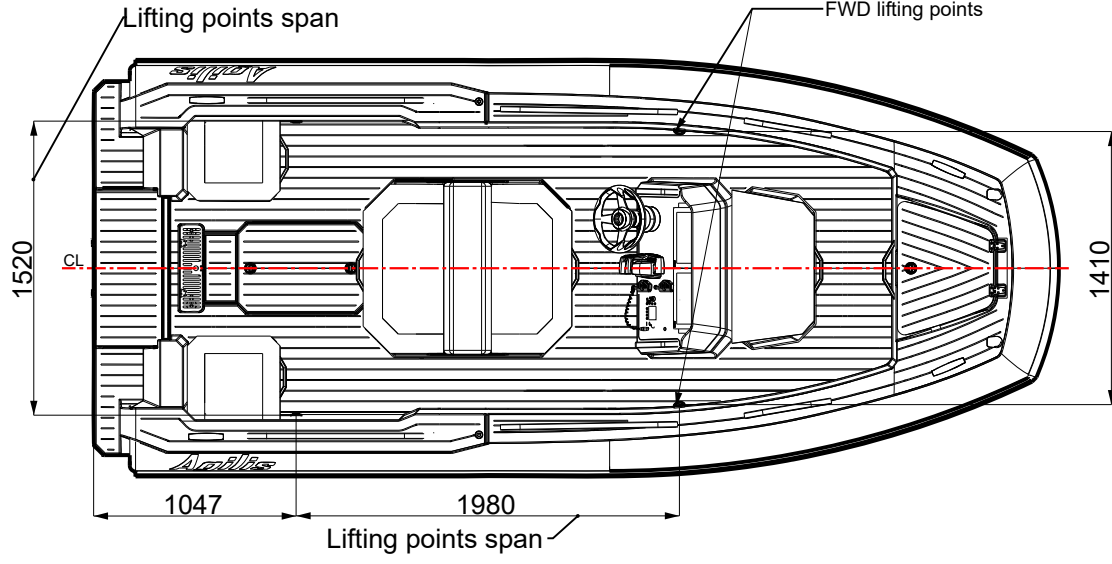

**Technical data:**

- 1.Length Overall:.....5.00 m, +/-1%
- 2.Beam Overall:.....2,2 m, +/-1%
- 3.Seating capacity:.....8+1
4. Empty craft mass:..... 1000 kg
5. Maximum load:.....700 kg (fuel excluded),
6. Maximum speed, V = 35 knots
7. CE Design Category "C"
- 8.Engine: MERCURY DESEL 2.0L (150 HP/110 kW)
9. Propulsion: Jet drive
10. Fuel tank capacity: .....70 litres, diesel
- 12.No. of tube Compartments:..... 5

UNLESS OTHERWISE SPECIFIED:		FINISH:	DEBURR AND BREAK SHARP EDGES		DO NOT SCALE DRAWING	REVISION
DIMENSIONS ARE IN MILLIMETERS					This drawing is the property of Agilis Jet Tenders GmbH Lorstolzstr. 27 52428 Jülich. This information must not be reproduced, distributed, or used for any purpose other than in conjunction with the boat or design for which it was drawn, without the owner's written consent.	
SURFACE FINISH:					TITLE:	
TOLERANCES:					AT500 - General Arrangement	
LINEAR:					DWG NO.	
ANGULAR:					AT500-000-001	
DRAWN:	NAME	SIGNATURE	DATE			A2
CHK'D:						
APP'VE:						
MFG:						
G.A:						
					MATERIAL:	
					WEIGHT:	
					SCALE:1:20	SHEET 1 OF 1